

## Design of Immittans Clcl Grid for Using in Constant Current Resonans Converters

Farhad Fateh,

Shahab Danesh Institute of Higher Education

Email:farhad.fateh4659@yahoo.com

Naser Eshghabadi

Azad Tehran University

**ABSTRACT**— Impedance-admittance converter is shortly termed as immittance converter. In this converter, the output current is proportional to the input voltage and the output voltage is proportional to the input current. The output current is thus independent of the load. This research evaluates the characteristics of a proposed  $\pi$ -CLCL immittance converter, which is a combination of the typical  $\pi$ - and T-type configurations, for constant current and dynamic load applications. The input-output characteristics and efficiency characteristics are analyzed and simulated. The characteristics are compared to that of the typical  $\pi$ - and T-type converters. The input-output characteristics and efficiency characteristics are then examined experimentally. It is observed that the experimental results agree with those of the simulation ones, and confirm that the  $\pi$ -CLCL configuration is more efficient than the typical  $\pi$ - and T-type immittance converters while maintaining a nearly constant output current and thus applicable for dynamic loads.

### Introduction

Impedance-admittance converter is shortly termed as immittance converter, where the term ‘immittance’ is a combination of the words ‘impedance’ and ‘admittance’. The term ‘immittance’ was first invented by Hendrik Wade Bode [1]. An immittance converter is a four-terminal network in which the input impedance is converted into the admittance of the load at the output terminals [2, 3]. The main characteristic of this converter is that at resonance frequency, the output current is proportional to the input voltage and the output voltage is proportional to the input current, which ensures that the output current is independent of the load. This feature of immittance converter makes it suitable in many power electronics applications especially where constant currents are needed [6-13]. The immittance conversion topology has become attractive in recent years as a novel means of power conversion because of its properties that it converts a constant voltage source to a constant current source and vice versa [2, 3]. Hence, the immittance converter may be utilized to convert a voltage source into a current source and vice versa when it is inserted into the high-frequency link part of a power electronics system [3]. In the communication field, an immittance converter is also known as a gyrator [4]. Some resonant converters have been shown to exhibit immittance conversion properties [5]. The immittance converter also has many constant current and dynamic load applications in power electronics and many other fields such as photovoltaic inverters [6], dc-dc converters [7], low-pass filters [7], induction heating, plasma generation [8], HID lamp ballasts [9], capacitor charging applications [10], noncontact energy transmission systems [11], high-voltage dc transmission link [12], and corona-discharge applications operating in the mega-hertz range [13]. A lumped-constant reactor L and capacitor C can be used for the implementation of an immittance converter in a compact design. Some lumped-constant configurations of the immittance converter have been studied previously [1-13]. There are four typical configurations of the immittance converter that consist of three lumped reactive elements namely T-LCL type,  $\pi$ -CLC type, T-CLC type and  $\pi$ -LCL type. Converters with more than four reactive elements are bigger, heavier and costlier and their analysis and design is more complicated [14]. Hence converters having more than four reactive elements have not been studied. The TLCL topology and its applications have been studied the most [15-17]. In this article, we propose a new configuration of the immittance converter, the  $\pi$ -CLCL configuration, which is a combination of the  $\pi$ -CLC and T-LCL type converters. The input/output voltage and current characteristics and the efficiency characteristics of the proposed  $\pi$ -CLCL immittance converter are analyzed both theoretically and experimentally. The characteristics are simulated and the simulation results are compared to that of the experimental ones. The characteristics of the  $\pi$ -CLCL configuration are also compared to that of the typical  $\pi$ -CLC type and T-LCL configurations.

### LC Lumped Immittance Converter

The immittance converter can be represented by the block diagram as shown in Figure 1. There are four typical configurations of the immittance circuit namely T-LCL type,  $\pi$ -CLC type, T-CLC type and  $\pi$ -LCL type. Figure 2 shows the circuit diagram of the above-mentioned four types of immittance converter.

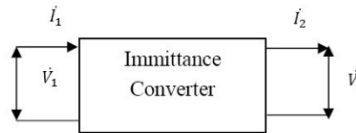

Figure 1. Four-terminal immittance converter

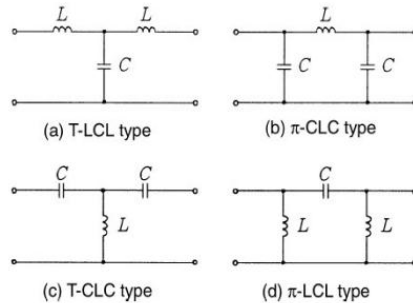

Figure 2. Typical configurations of immittance converter

The four-terminal matrix of the immittance converter, shown in Figures 1 & 2, can be represented by,

$$\begin{bmatrix} \dot{V}_1 \\ \dot{I}_1 \end{bmatrix} = \begin{bmatrix} A & B \\ C & D \end{bmatrix} \begin{bmatrix} \dot{V}_2 \\ \dot{I}_2 \end{bmatrix} \tag{1}$$

Here  $\dot{V}_1$ ,  $\dot{I}_1$ ,  $\dot{V}_2$  and  $\dot{I}_2$  are the voltages and currents at the input and output ports respectively; A is the voltage gain, B is the transfer impedance, C is the transfer admittance and D is the reverse current gain. At resonance frequency and under ideal conditions ( $Q_1, Q_2 \gg 1$ , where  $Q_s$  are the quality factors of the circuits), the immittance converter can be described as,

$$\begin{bmatrix} \dot{V}_1 \\ \dot{I}_1 \end{bmatrix} = \begin{bmatrix} 0 & \pm jZ_0 \\ \pm j\frac{1}{Z_0} & 0 \end{bmatrix} \begin{bmatrix} \dot{V}_2 \\ \dot{I}_2 \end{bmatrix} \tag{2}$$

where,  $Z_0 (= \sqrt{L/C})$  is the characteristic impedance of the immittance conversion circuit. Equation (2) can be rewritten as,

$$\begin{aligned} \dot{V}_1 &= \pm jZ_0 \dot{I}_2 \\ \dot{I}_1 &= \pm j\frac{1}{Z_0} \dot{V}_2 \end{aligned} \tag{3}$$

From (3), output current and voltage expressions are,

$$\begin{aligned} \dot{I}_2 &= \mp j\frac{1}{Z_0} \dot{V}_1 \\ \dot{V}_2 &= \mp jZ_0 \dot{I}_1 \end{aligned} \tag{4}$$

From (4), it can be seen that the output current is proportional to the input voltage while output voltage is proportional to the input current. This means that if the input voltage is constant then a constant output current proportional to the input voltage is achieved and if the input current is constant, a constant output voltage proportional to the input current is achieved. Therefore, the output current and voltage are independent of the load [14, 18].

**$\pi$ -CLC Immittance Converter**

By analyzing the respective immittance conversion circuit using Kirchoff’s laws it is found that the load current and the efficiency of the  $\pi$ -CLC immittance converter can be written as,

$$I_2 \cong \frac{V_1}{Z_0} \left( 1 - \frac{1}{Q} \frac{Z_2}{Z_0} \right) \tag{5}$$

$$\eta \cong \frac{1}{1 + \frac{1}{Q} \frac{Z_2}{Z_0} + \frac{1}{Q} \frac{Z_0}{Z_2}} \tag{6}$$

Where, the load impedance is defined as  $Z_2 = \frac{V_2}{I_2}$  and Q, the quality factor of the circuit, is defined as Q.

**T-LCL Immittance Converter**

Similar to the  $\pi$ -CLC configuration, the load current equation and the efficiency of the T-LCL

immittance converter can be written as,

$$I_1 \cong \frac{V_1}{Z_0} \left( 1 - \frac{1}{Q_1} \frac{Z_2}{Z_0} \right) \quad (7)$$

$$\eta \cong \frac{1}{1 + \frac{1}{Q_1} \frac{Z_2}{Z_0} + \frac{1}{Q_2} \frac{Z_0}{Z_2}} \quad (8)$$

**$\pi$ -LCL Immittance Converter**

The load current and the efficiency of the  $\pi$ -LCL immittance converter can similarly be written as,

$$I_2 = \frac{V_1}{Z_0} \left( 1 - \frac{Q_2}{Q_2^2 + 1} \frac{Z_2}{Z_0} \right) \quad (9)$$

$$\eta \cong \frac{1}{1 + \frac{Q_1}{Q_1^2 + 1} \frac{Z_2}{Z_0} + \frac{Q_2}{Q_2^2 + 1} \frac{Z_0}{Z_2}} \quad (10)$$

**T-CLC Immittance Converter**

Using circuit analysis techniques in a similar manner, the load current equation and the efficiency of the T-CLC immittance converter is found to be,

$$I_2 = \frac{V_1}{Z_0} \left( 1 - \frac{Q}{Q^2 + 1} \frac{Z_2}{Z_0} \right) \quad (11)$$

$$\eta = \frac{V_2 I_2}{V_1 I_1} = \frac{1}{1 + \frac{Q}{Q^2 + 1} \frac{Z_2}{Z_0} + \frac{Q}{Q^2 + 1} \frac{Z_0}{Z_2}} \quad (12)$$

For the special case where  $Q_1=Q_2=Q$  and  $Z_0=Z_2$ , for high values of  $Q$ , the efficiency characteristic of all four configurations is the same and approximated as,

$$\eta \cong \frac{1}{1 + \frac{2}{Q}} \cong 1 - \frac{2}{Q} \quad (13)$$

**Proposed  $\pi$ -CLCL Immittance Converter**

The proposed  $\pi$ -CLCL immittance converter is shown in Figure 3, where  $m$  is an arbitrary coefficient in the range of 0 to 1. The inductors are assumed to have series internal resistances  $r_1$  and  $r_2$  respectively; and the capacitors are assumed to be ideal. This  $\pi$ -CLCL converter is a combination of the typical  $\pi$ -CLC and TLCL configurations. The proposed immittance converter corresponds to the T-LCL type converter at  $m=0$ , and to the  $\pi$ -CLC type at  $m=1$  as shown in Figure 2(a) and Figure 2(b), respectively.

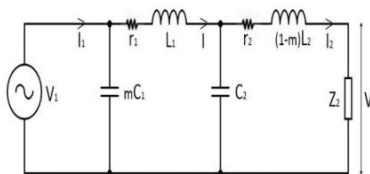

Figure 3.  $\pi$ -CLCL type immittance converter

**Resonant Frequency Characteristics**

By analyzing the proposed  $\pi$ -CLCL immittance converter circuit using Kirchhoff's laws, the A , B , C , D parameters are found to be,

$$\begin{aligned} \dot{A} &= j\omega C(r_1 + j\omega L) + 1 \\ \dot{B} &= j\omega C(r_1 + j\omega L)\{r_2 + j\omega L(1 - m)\} + \{r_1 + j\omega L\} + \{r_2 + j\omega L(1 - m)\} \\ \dot{C} &= j^2\omega^2 m C^2(r_1 + j\omega L) + j\omega m C + j\omega C \\ \dot{D} &= j^2\omega^2 m C^2(r_1 + j\omega L)\{r_2 + j\omega L(1 - m)\} + j\omega m C\{r_1 + j\omega L\} + j\omega m C\{r_2 + j\omega L(1 - m)\} \\ &\quad + j\omega C\{r_2 + j\omega(1 - m)L\} + 1 \end{aligned} \quad (14)$$

At resonant frequency (taking resonant frequency  $\omega$ ),

$$\omega^2 = \frac{1}{LC}; Z_0 = \sqrt{\frac{L}{C}}; Q_1 = \frac{\omega L}{r_1}; Q_2 = \frac{\omega(1-m)L}{r_2}$$

Replacing the above parameters in Eq. (14), and ignoring the real parts since  $Q_1, Q_2 \gg 1$ , the A, B, C, D parameters at resonant frequency can be approximated as,

$$\begin{aligned} \dot{A} &= j\frac{1}{Q_1} \\ \dot{B} &= jZ_0 \left[ 1 + \frac{(1-m)}{Q_1 Q_2} - j\frac{m}{Q_1} \right] \\ \dot{C} &= j\frac{1}{Z_0} \left( 1 + j\frac{m}{Q_1} \right) \\ \dot{D} &= j\frac{1}{Q_2} + jm \left( \frac{m}{Q_1} - \frac{1}{Q_2} \right) - \frac{m(1-m)}{Q_1 Q_2} \end{aligned} \quad (15)$$

Therefore, the four-terminal matrix of the network becomes:

$$\begin{bmatrix} \dot{V}_1 \\ \dot{I}_1 \end{bmatrix} = \begin{bmatrix} j\frac{1}{Q_1} & jZ_0 \\ j\frac{1}{Z_0} & j\frac{1}{Q_2} + jm \left( \frac{m}{Q_1} - \frac{1}{Q_2} \right) \end{bmatrix} \begin{bmatrix} \dot{V}_2 \\ \dot{I}_2 \end{bmatrix} \quad (16)$$

If Q1 and Q2 are high (>100) then A=D=0 and BC=1 at any value of m which is the properties of an ideal immittance converter as shown in Eq. (2).

### Input-Output Characteristics

When the load impedance  $Z_L$  is connected to the output terminals,  $V_1$  and  $I_1$  can be obtained from Eq (16) as,

$$\dot{V}_1 = jI_2 \left( 1 + \frac{1}{Q_1} \frac{Z_2}{Z_0} \right) \quad (17)$$

$$I_1 = j\frac{1}{Z_0} \dot{V}_2 \left[ 1 + \left\{ \frac{1}{Q_2} + m \left( \frac{m}{Q_1} - \frac{1}{Q_2} \right) \right\} \frac{Z_0}{Z_2} \right] \quad (18)$$

From Eqs. (17) & (18), the output current and voltage are found to be,

$$I_2 \cong \frac{V_1}{Z_0} \left( 1 - \frac{1}{Q_1} \frac{Z_2}{Z_0} \right) \quad (19)$$

$$V_2 \cong I_1 Z_0 \left[ 1 - \left\{ \frac{1}{Q_2} + m \left( \frac{m}{Q_1} - \frac{1}{Q_2} \right) \right\} \frac{Z_0}{Z_2} \right] \quad (20)$$

The first term of the output current and output voltage is the ideal term while the second term is the loss term resulting from the internal resistance of the inductances. When the internal resistance is negligible or zero, the quality factor becomes high or infinity. Under this condition, the second term becomes negligible or zero giving the ideal immittance condition as shown in Eq. (4).

### Efficiency Characteristic

Using Eq. (19),(20) and ignoring higher order terms of Q (since Q1, Q2>>1), the efficiency of the proposed  $\pi$ -CLCL immittance converter can be written as,

$$\eta = \frac{V_2 I_2}{V_1 I_1} \cong \frac{1}{1 + \frac{1}{Q_1} \frac{Z_2}{Z_0} + \left\{ \frac{1}{Q_2} + m \left( \frac{m}{Q_1} - \frac{1}{Q_2} \right) \right\} \frac{Z_0}{Z_2}} \quad (21)$$

Differentiating Eq. (21) with respect to Z2 and taking the derivative equal to 0, it is found that the maximum efficiency occurs when,

$$Z_2 = Z_0 \left( m^2 - m \frac{Q_1}{Q_2} + \frac{Q_1}{Q_2} \right)^{1/2} \quad (22)$$

Therefore, from Eqs. (21) & (22), maximum efficiency,  $\eta$  is found to be,

$$\eta_m = \frac{\left( m^2 - \frac{Q_1}{Q_2} m + \frac{Q_1}{Q_2} \right)^{1/2}}{\left( m^2 - \frac{Q_1}{Q_2} m + \frac{Q_1}{Q_2} \right)^{1/2} + 2 \left( \frac{1}{Q_1} m^2 - \frac{1}{Q_2} m + \frac{1}{Q_2} \right)} \quad (23)$$

For a special case, where Q1=Q2=Q, Z0=Z2 and m=0.5, the efficiency characteristic of the  $\pi$ -CLCL converter can be written using the binomial theorem as,

$$\eta \cong \frac{1}{1 + \frac{1.75}{Q}} \cong 1 - \frac{1.75}{Q} \quad (24)$$

For obtaining highest efficiency at the characteristic impedance Z0, it is found that,

$$\left( m^2 - m \frac{Q_1}{Q_2} + \frac{Q_1}{Q_2} \right)^{1/2} = 1 \quad (25)$$

Solving (25) with m=0.5 gives

$$Q_1 = 1.5Q_2 \quad (26)$$

The above condition will give maximum efficiency at resonance. The efficiency characteristic of the  $\pi$ -CLCL converter in this case at  $Z_0=Z_2$  can be written using the binomial theorem as,

$$\eta_{\max} \cong 1 - \frac{1.333}{Q_2} \tag{27}$$

Comparing Eq.(27) with (13), it is clear that the maximum efficiency of the proposed immittance converter is greater the efficiency of the four basic topologies described in section 2.

**Results and Discussions**

The load current characteristics and the efficiency characteristics of each configuration were simulated using MATLAB. The characteristic impedance  $Z_0$  was taken as  $Z_0=20.8\Omega$  and  $m$  was taken to be  $m=0.5$ . Load was varied from  $0\Omega$  to  $60\Omega$  and input voltage was taken to be  $V_1=220V$  rms. Prototypes of the  $\pi$ -CLCL,  $\pi$ -CLC and T-LCL configurations were built using inductors and capacitors available in the market. The experimental parameters for the  $\pi$ -CLCL topology are listed in Table 1. An inductor of  $195\mu F$  was used because it was the maximum value found in the market. Since  $Q=0.5$  a high  $L$  results in a higher  $Q$ . A  $92.4\mu F$  inductor was selected since an inductor half the value of the larger one was needed. Capacitor values were selected so as to keep the characteristic impedance equal to  $20.8\Omega$ . The quality factors were found to be  $Q_1=12.6$  and  $Q_2=35.3$ .

Table 1. Circuit Parameters for Experiments

Circuit parameters	Values	
$m$	0.5	
Resonant frequency $f_r$ [kHz]	17.028	
Inductors $L$ [ $\mu H$ ]	$L_1=195$	$(1-m)L_2=92.4$
Capacitors $C$ [ $\mu F$ ]	$mC_1=0.193$	$C_2=0.448$
Characteristic Impedance $Z_0$ [ $\Omega$ ]	20.8	

**Load Current Characteristics**

The load current characteristics of the  $\pi$ -CLCL type immittance converter for  $Q_1=Q_2=Q$  are shown in Figure 4. As can be seen from the graphs the load current remains fairly constant as load is increased up to three times the characteristic impedance. Ideally, the current should remain constant. However, because of the loss due to the quality factor  $Q$  the current decreases slightly with load. Also, it is obvious from the figure that the higher the  $Q$  value, the less is the decrease in current which means the less is the effect of the loss term of output current. For  $Q=150$  the load current graph is almost a straight line. Therefore, since the current deviates only slightly with load, it can be said that the converter provides output current independent of the load.

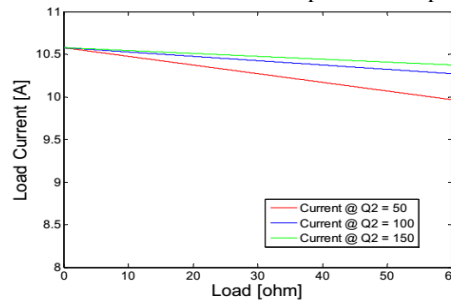

Figure 4. Load current,  $I_2$ , characteristics curve of  $\pi$ -CLCL type immittance converter

Figure 5 is a comparison of the simulation results and experimental results of the output current of the  $\pi$ -CLCL immittance converter. Ideally, according to the simulation, if quality factor is extremely high, the load current should remain constant at  $40.7mA$ . However, with a quality factor of  $Q_1=12.6$  and  $Q_2= 35.3$ , the load current decreases slightly with load. As can be seen from the figure, the output current obtained from the experiments shows little deviation as load is increased to three times the resonant frequency. Thus, the experimental data is in conformity with the simulation results.

**Efficiency Characteristics**

Figure 6 illustrates the graph of efficiency against the factor  $m$  considering  $Q_1=Q_2=Q$ . As can be seen from the figure that for equal quality factors, the maximum efficiency occurs at  $m=0.5$ .

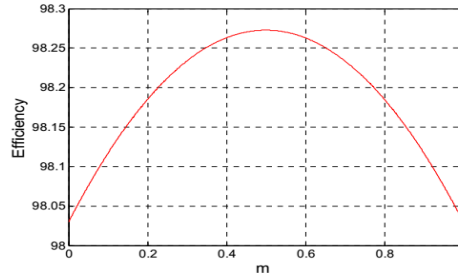

Figure 5. Efficiency versus  $m$  curve of  $\pi$ -CLCL type immittance converter

Figures 7~9 compare the efficiency characteristics of the  $\pi$ -CLCL immittance converter with that of the typical four configurations for different  $Q$  values. The blue curves represent the efficiency of the typical four configurations; the red curves represent the efficiency of the  $\pi$ -CLCL type immittance converter having  $Q_1=Q_2$  while the green curves represent the efficiency of the  $\pi$ -CLCL type converter having  $Q_1=1.5Q_2$  as derived in (26). As can be seen from the simulation results, the  $\pi$ -CLCL type has higher efficiency than the typical four configurations for all three values of  $Q$ . The higher the value of  $Q$  the better is the efficiency. Also, the converter with  $Q_1=1.5Q_2$  has higher efficiency than that with  $Q_1=Q_2$ . For the case  $Q_1=1.5Q_2$ , maximum efficiency occurs when  $Z_2=20.8\Omega$ , which is the characteristic impedance of the circuit whereas for the case  $Q_1=Q_2$  maximum efficiency does not occur when  $Z_2=Z_0$  but at  $Z_2=18.0\Omega$ .

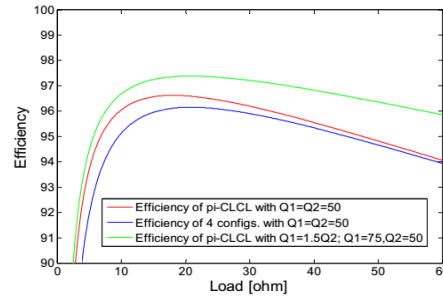

Figure 7. Comparison of efficiency characteristics of  $\pi$ -CLCL type immittance converter and typical configurations for  $Q = 50$

The efficiency characteristics of the  $\pi$ -CLCL converter obtained experimentally is compared to the simulation result in Figure 10. The experimental data demonstrates the trend of the simulation result. Figure 11 shows the comparison of the experimental values of the efficiency of the  $\pi$ -CLCL,  $\pi$ -CLC and T-LCL configurations. As can be seen from the figure, the  $\pi$ -CLCL configuration has higher efficiency than both the  $\pi$ -CLC and T-LCL type converters as expected. Figure 12 presents the efficiency of the  $\pi$ -CLCL converter at resonant frequency and at frequencies  $\pm 5\%$  of the resonant frequency. Figure 13 portrays the efficiency of the converter at resonant frequency and at  $\pm 10\%$  of the resonant frequency. There is very little difference in the efficiency in all five cases indicating that the efficiency is not much affected by the changes in frequency.

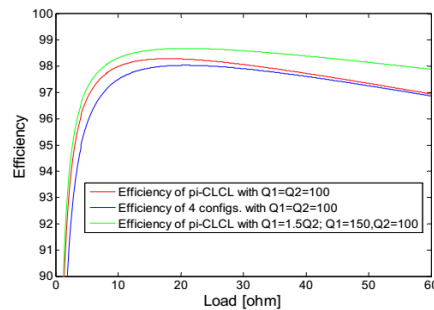

Figure 8. Comparison of efficiency characteristics of  $\pi$ -CLCL type immittance converter and typical configurations for  $Q = 100$

## Conclusion

This paper evaluates the characteristics of the  $\pi$ -CLCL type immittance converter using simulation and experiments. The study ensures immittance conversion of the circuit at resonant frequency. The experimental data reinforces the results obtained from simulations. The output current remains fairly constant as load is increased up to three times the characteristic impedance. Therefore, it can be said that the output current is independent of the load. Thus, the  $\pi$ -CLCL configuration of the immittance converter can be used for constant current and dynamic load applications. The study confirms that the  $\pi$ -CLCL configuration is more efficient than the  $\pi$ -CLC and T-LCL configurations. Furthermore, the efficiency is not much affected by the changes in frequency. Maximum efficiency and the load at which maximum efficiency occurs both depend on the ratio of the two quality factors. The condition  $Q_1=1.5Q_2$  gives better efficiency than  $Q_1=Q_2$ . If quality factors can be improved, the efficiency of the converter will increase substantially. Therefore, a highly efficient converter can be built using the proposed  $\pi$ -CLCL topology of the immittance converter if inductors having higher quality factors are used.

## References

1. HW Bode. "Network Analysis and Feedback Amplifier Design". Princeton: Van Nostran (1945).
2. K Ohnishi et al. "Efficiency characteristics of immittance converter". Proc Japan IAS Conference. 1998; 215.
3. H Irie et al. "Immittance converter suitable for power electronics". Trans IEE Japan. 1997; 117-D: 962-969.
4. D Shmilovits et al. "A converter topology with gyrator characteristics". PESC'96. pp. 426-430.
5. H Pollock. "Simple constant frequency constant current load-resonant power supply under variable load conditions". Electron. Lett. 1997; 33(18): 1505-1506.
6. H Irie et al. "Utility interactive inverter using immittance converter for photovoltaic power system". Trans IEE Japan. 120-D: 410-416.
7. H Yamana et al. "Immittance converter in a switching mode power converter". National Convention Record of IEEJ. 1996; 817.
8. MA Razzak et al. "Efficient Radio Frequency Inductive Discharges in Near Atmospheric Pressure Using Immittance Conversion Topology". J. Plasma Fusion Res. 2005; 81(3): 204-211.
9. H Ohguchi et al. "A high-frequency electronic ballast for HID lamp based on a  $\lambda/4$ -long distributed constant line". IEEE Trans. Power Electron. 1998; 13(6): 1023-1029.
10. M Borage et al. "A constant-current, constant voltage half-bridge resonant power supply for capacitor charging". Proc. Inst. Elect. Eng. -Elect. Power. Appl. 2006; 153(3): 343-347.
11. H Irie et al. "Non-contact energy transfer system using immittance converter". Elect. Eng. Japan. 2001; 136(4):58-64.
12. N Kimura et al. "Analysis of HVDC converter with immittance conversion link". Proc. EPE. 1999; 1-9.
13. Y Sakamoto et al. "A 13.565 MHz current-output type inverter utilizing an immittance conversion element". Proc.Int. EPE-PEMC. 2008; 288-294.
14. M Borage et al. "Resonant Immittance Converter Topologies". IEEE Trans. Industrial Electronics. 2001; 58(3):971-978.
15. M Borage et al. "Analysis and design of LCL-T resonant converter as a constant-current power supply". IEEE Trans. Ind. Electron. 2005; 52(6): 1547-1554.
16. M Borage et al. "LCL-T resonant converter with clamp diodes: A novel constant-current power supply with inherent constant-voltage limit". IEEE Trans. Ind. Electron. 2007; 54(2): 741-746.
17. M Borage et al. "Design of LCL-T resonant converter including the effect of transformer winding capacitance". IEEE Trans. Ind. Electron. 2009; 56(5): 1420-1427.